



**CITY OF EAST PROVIDENCE
SUPPLY AND DELIVER VERTICAL GRANITE CURBING TO BOLD POINT PARK
SPECIFICATIONS
RFB EP21/22-12R
REQUEST FOR BIDS
BID OPENING THURSDAY, MAY 26, 2022 AT 11:00AM**

SCOPE OF WORK

The City of East Providence is requesting bids from qualified granite companies/contractors to supply and deliver Vertical Granite Curbing to Bold Point Park located near 500 Waterfront Drive, East Providence, RI 02914. The quantities and descriptions can be found on the Bid form.

The Contractor shall supply and deliver the Vertical Granite Curbing to Bold Point Park during City working hours from 7:30AM-3:30PM.

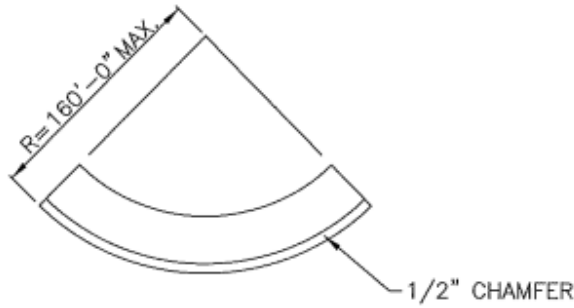
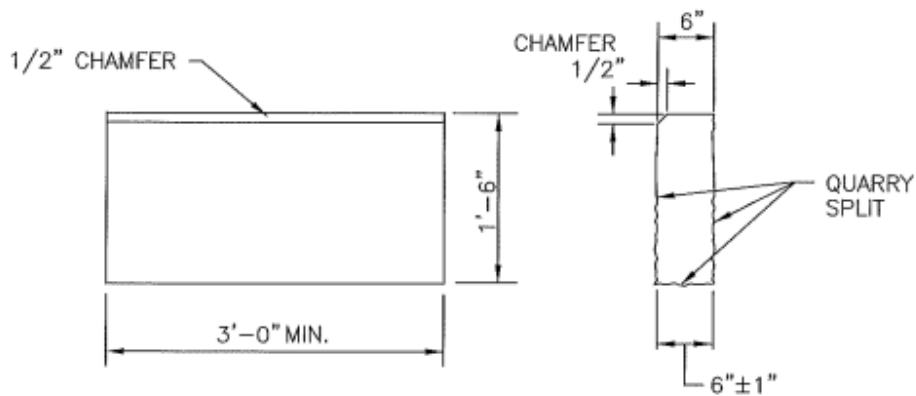

CIRCULAR CURB

NOTES:

1. SHALL BE IN ACCORDANCE WITH SECTION 906 OF THE R.I. STANDARD SPECIFICATIONS.
2. TOP SURFACE TO BE DRESSED BY SAW. REMAINDER MAY BE QUARRY SPLIT.
3. MINIMUM LENGTH OF STRAIGHT OR CIRCULAR PIECES TO BE 3'-0".
4. CIRCULAR CURB IS REQUIRED ON CURVES WITH RADII OF 160'-0" OR LESS. STRAIGHT CURB TO BE USED ON CURVES OF MORE THAN 160'-0" RADIUS.

RHODE ISLAND DEPARTMENT OF TRANSPORTATION

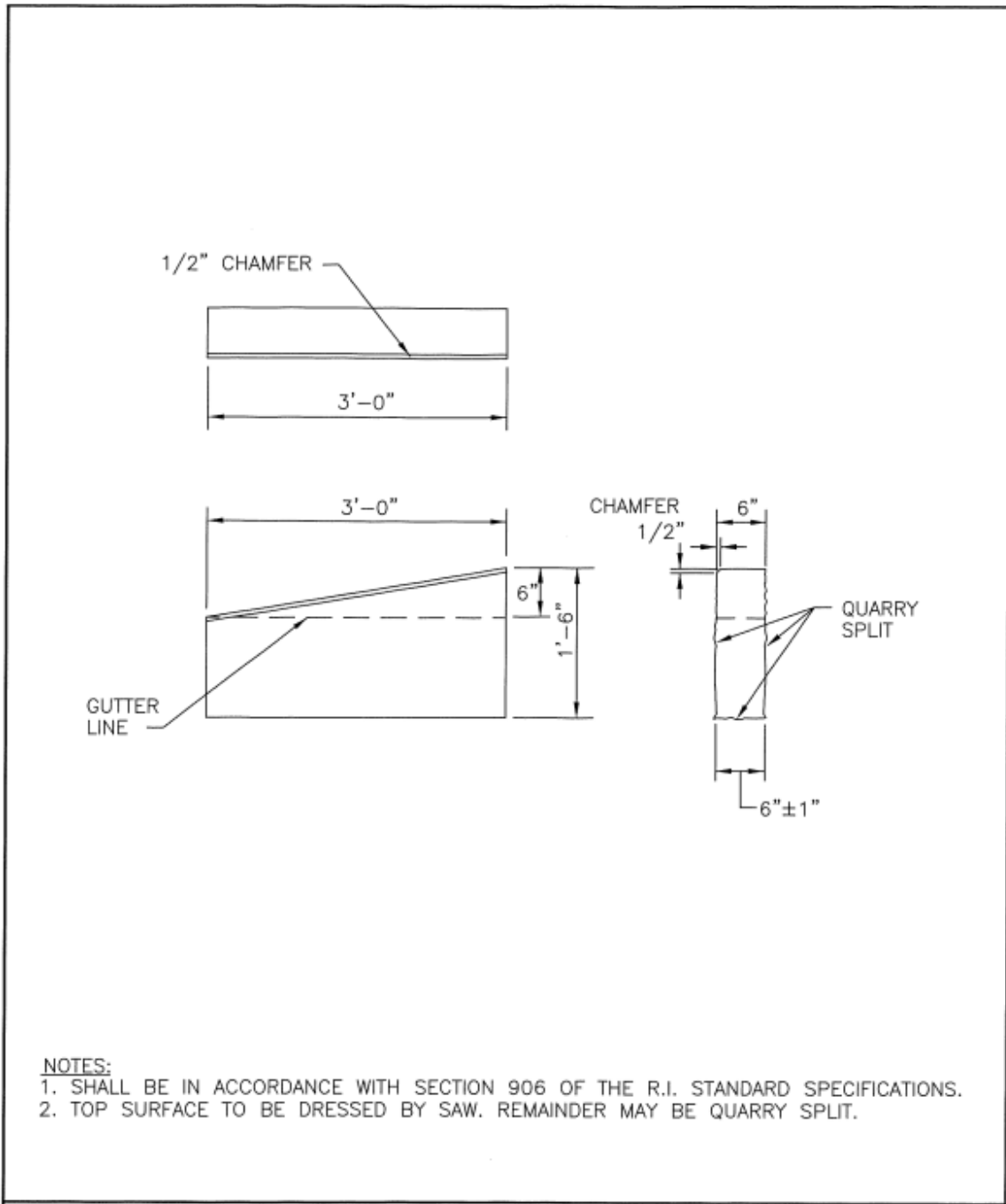

REVISIONS			GRANITE CURB		
NO.	BY	DATE			
1	MLP	Mar 2005	 CHIEF ENGINEER TRANSPORTATION		
2	MLP	Sep 2012			
			 CHIEF DESIGN ENGINEER TRANSPORTATION		
			JUNE 15, 1998 ISSUE DATE		



NOTES:

1. SHALL BE IN ACCORDANCE WITH SECTION 906 OF THE R.I. STANDARD SPECIFICATIONS.
2. TOP SURFACE TO BE DRESSED BY SAW. REMAINDER MAY BE QUARRY SPLIT.

RHODE ISLAND DEPARTMENT OF TRANSPORTATION

REVISIONS			3'-0" GRANITE TRANSITION CURB	
NO.	BY	DATE		
1	MLP	Mar 2005	 CHIEF ENGINEER TRANSPORTATION	 CHIEF DESIGN ENGINEER TRANSPORTATION
2	MLP	Jun 2010		
3	MLP	Sep 2012		
			JUNE 15, 1998	ISSUE DATE

QUALIFICATIONS

The proposal shall include, at a minimum, the following information with regards to qualifications and references:

- A list of at least three (3) client references including two (2) government clients where you have provided similar goods and services. The reference information shall include the name, address, contact name, email address, phone number.
- Identification of any and all parent or subsidiary relationships.

GENERAL CONDITIONS

1. The City reserves the right to reject any/or all companies, to waive any informality in the proposal statement and to accept the proposal of any company based on what the City deems to be in its best interest.
2. The City reserves the right to accept all or part of any proposal and to negotiate a contract for services and cost with the selected Contractor.
3. The Vendor shall provide all necessary personnel, sub-contractors, materials and equipment to perform and complete all work under this proposal.
4. All original documents and drawings shall become the property of the City after completion of the contractor's work.
5. The Vendor shall be prepared to commence work immediately upon execution of a contract with the City.
6. The Vendor shall forward any questions regarding this request for bids in a formal request for information (RFI) addressed to:

Erik Skadberg, Deputy Director of Public Works/City Engineer
145 Taunton Avenue, East Providence, RI 02914
eskadberg@eastprovidenceri.gov
No later than **TUESDAY, MAY 24, 2022 at 4:00PM.**